

01 BENCH BOLTED DOWN TO CONCRETE SLAB
ELEVATION 1:20

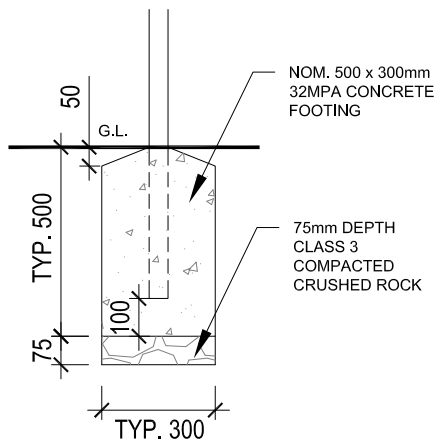

02 EXTENDED LEG FOOTING DETAIL
ELEVATION 1:20

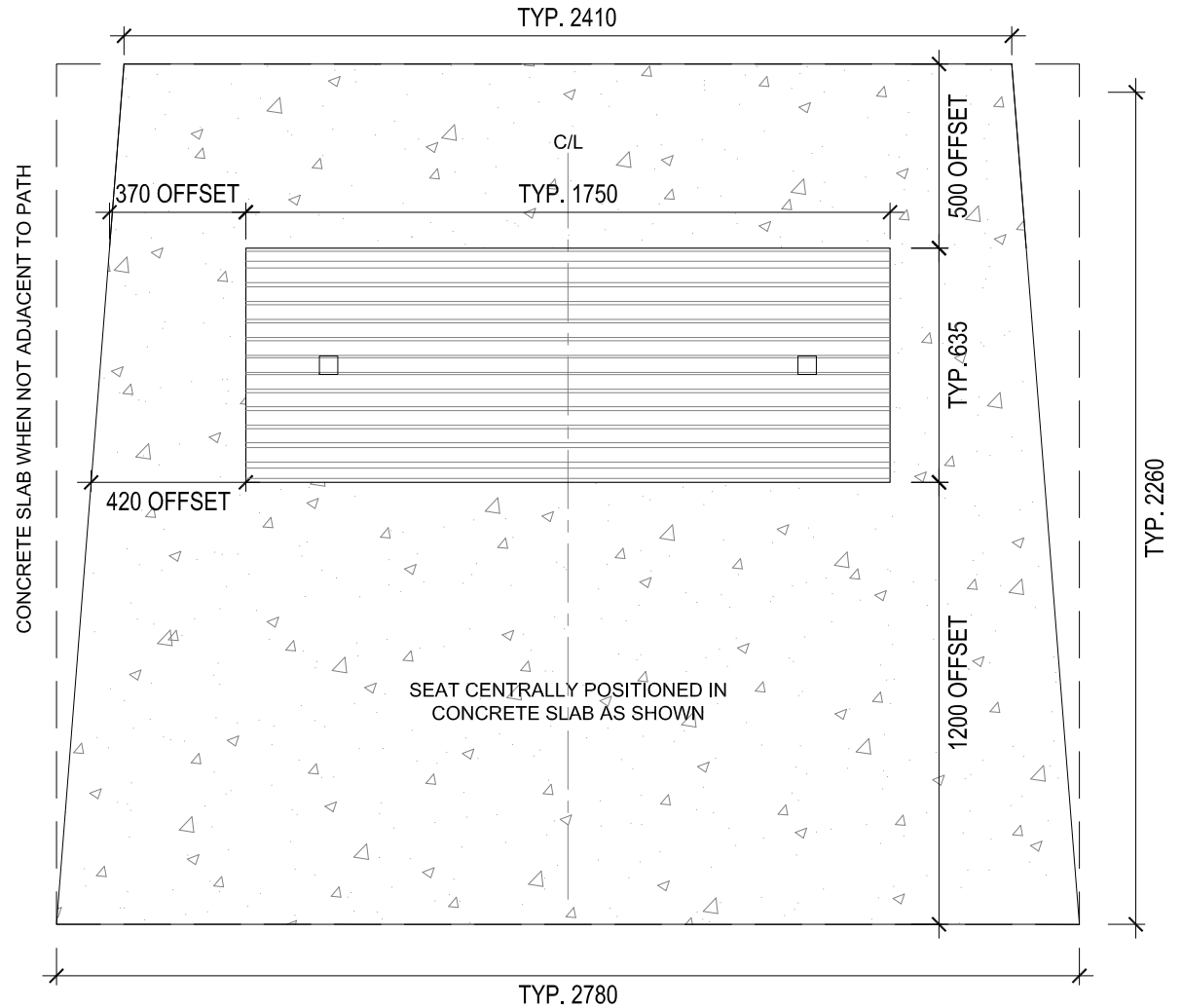

03 SEAT LAYOUT: ADJACENT TO PATH
PLAN 1:20